

MANUAL NO.
INS9310

ADJUSTING INSTRUCTIONS

STYLES

SP151H829M032
SP151H830M032
SP151H829M040
SP151H830M040
SP161S800M032
SP161S800M040
SP161S800M048C
SP161S900M032C
SP161S900M040C
SP161S900M048C
SP161H829M032
SP161H830M032
SP161H829M040
SP161H830M040
SP172S800MAAC
SP172S800MACC
SP172S800MADC
SP172S900MACC
SP172S900MADC
SP172S900MAEC
SP172S800MBDC
SP172S900MBDC
SP172S900HAC
SP172S900HAD
SP172S900HAE
SP172S900HBD
SP172S900HBE

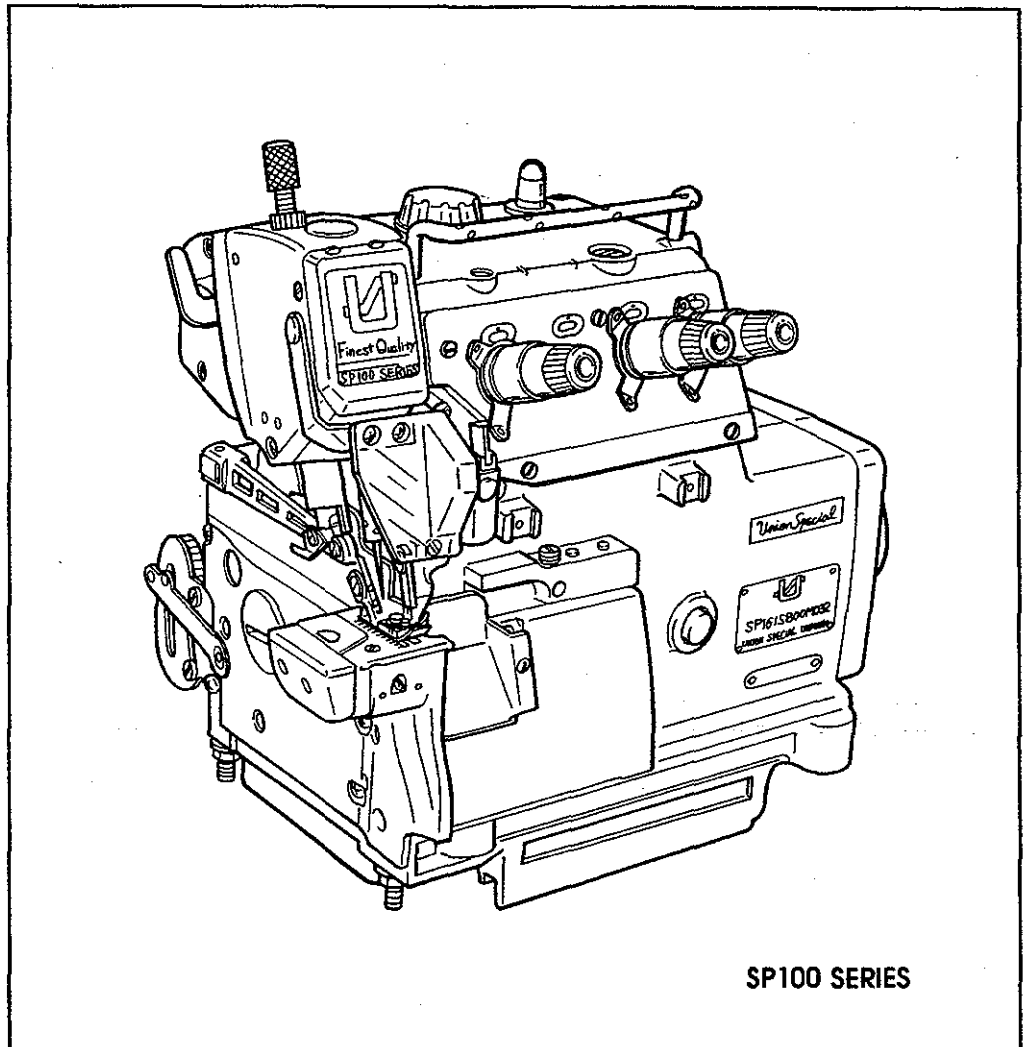

SP100 SERIES



Union Special
INDUSTRIAL SEWING EQUIPMENT

TABLE OF CONTENTS



SAFETY RULES

Page

1 — 2

BEFORE OPERATION	3
CAUTIONS IN OPERATION	3
1. INSTALLING THE FRAME SUPPORT PLATE	4
2. MOTOR PULLEY AND V BELT	4
3. ATTACHING THE BELT COVER	5
4. INSTALLING THE PEDALS	5
5. LUBRICATION	5
6. ATTACHING NEEDLES	6
7. THREADING THE MACHINE	6
8. PRESSER FOOT PRESSURE AND LIFTER	7
9. ADJUSTING THE STITCH LENGTH	7
10. DIFFERENTIAL FEED MECHANISM	7
11. KNIVES AND OVEREDGE WIDTH	8
12. SPECIFICATIONS	8

Manual No. INS9310 Adjusting Instructions for the SP100 Series Machines

First Edition Copyright 1993

By

Union Special Corporation Rights Reserved In All Countries

Printed in Japan October 1993

PREFACE

This adjusting manual has been prepared to guide you while adjusting the SP100 Series machines. It can be used in conjunction with Union Special Illustrated Parts Manual PRT9311.

This manual explains in detail the proper setting for each of the components related to forming the stitch and completing the functions of the machine. Illustrations are used to show the adjustments and reference letters are used to point out specific items discussed.

Careful attention to the instructions for operating and adjusting these machines will enable you to maintain the superior performance and reliability designed and built into every Union Special machine.

Adjustments are presented in sequence so that a logical progression is accomplished. Some adjustments performed out of sequence may have an adverse effect on the function of the other related parts.

This manual has been comprised on the basis of available information. Changes in design and/or improvements may incorporate a slight modification of configuration in illustrations or part numbers.

On the following pages will be found illustrations and terminology used in describing the adjustments for the SP100 Series machines.

SAFETY RULES



General Operating Directions

The sewing machines described in this manual are prohibited until it has been ascertained, that the sewing units in which these sewing machines will be built-in have conformed with the EC Council Directives (89/392/EEC, Annex II B).

1. Before putting the machines described in this manual into service carefully read the instructions. The starting of each machine is only permitted after taking notice of the instructions and by qualified operators.

IMPORTANT! Before putting into service also read the safety rules and instruction from the motor supplier.

2. Observe the national safety rules valid for your country.
3. Each machine is only allowed to be used as foreseen. The foreseen use of the particular machine is described in paragraph "STYLES OF MACHINES" of this manual. Another use, going beyond the description is not as foreseen.
4. All safety devices must be in position when the machine is ready for work or in operation. The operation without the appertaining safety devices is not allowed.
5. All safety devices are components of the sewing machines: Fingerguard, needle lever eyelet guard, needle bar guard, needle break protection shield, handwheel-belt guard.
6. When gauge parts are exchanged (e.g. needle, presser foot, needle plate, feed dog and bobbin) during threading, when the operator leaves the workplace, and during service work, the machine must be isolated for the main power by switching off the main switch or disconnecting the main plug. On mechanically operated clutch motors without a start inhibitor it is necessary to wait until the motor has stopped.

7. Wear safety glasses.
8. In case of machine conversions and changes all valid safety rules must be considered. Conversions and changes are made at your own risk.
9. Commissioning of the sewing head is prohibited until such time as the entire sewing unit is found to comply with EC regulations.
10. The warning hints in the instructions are marked with one of these two symbols.



Items require special attention



Danger of injury to operative or service staff

Be sure to observe and adhere to these indications and to the generally applicable regulations.

Special Operating Directions

11. For the following the machine has to be disconnected from the power supply by turning off the main switch or by pulling out the main plug:
 - 11.1 For threading needle(s), looper, spreader etc.
 - 11.2 For replacing sewing tools such as needle, presser foot, throat plate, looper, spreader, feed dog, needle guard, folder, fabric guide etc.
 - 11.3 When leaving the workplace and when the workplace is unattended.
 - 11.4 For maintenance work.
 - 11.5 When using clutch motors without actuation lock, wait until the motor is stopped totally.

General Maintenance Directions

12. Maintenance, repair and conversion works (see item 8) must be done only by trained technicians or special skilled personnel under consideration of the instructions.
13. Any work on the electrical equipment must be done by electricians or under direction and supervision of special skilled personnel.

Special Maintenance Directions

14. Work on parts and equipment under electrical tension is not permitted. Permissible exceptions are described in the applicable sections of standard sheet DIN VDE 0105.
15. Before doing maintenance and repair work on the pneumatic equipment, the machine has to be disconnected from the compressed air supply. In case of existing residual air pressure after disconnecting from compressed air supply (e.g. pneumatic equipment with air tank), it has to be removed by bleeding.

Exceptions are only allowed for adjusting work and function checks done by special skilled personnel.

Standards

17. The sewing machines described in this manual are built according to the following standards:
 - EN292-2 Safety of machinery-basic concepts, general principles for design.
 - IEC204-3-1/EN60204-3-1 Electrical equipment of industrial machines. Part 3: Particular requirements for sewing machines, units and systems.

BEFORE OPERATION

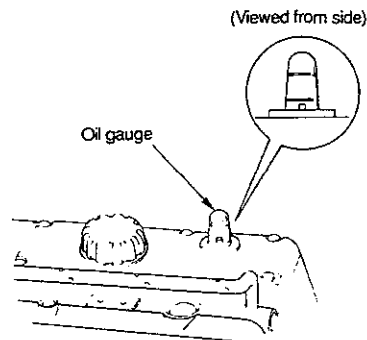

1. If the pointer bar of the oil gauge comes down under the lower marker line when observing the oil gauge from sideward, supply oil referring to the description of "5. Lubrication."

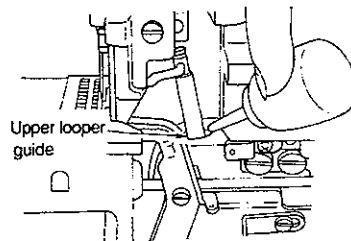
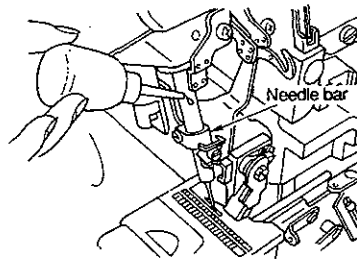

2. Apply two or three drops of oil to the needle bar and upper looper guide when operating the machine for the first time after setup or after a long period of disuse.

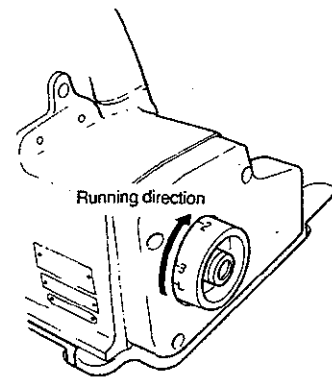

3. The correct machine running direction is such that the handwheel turns clockwise as viewed from the handwheel's side. Never run the machine in the reverse direction.

CAUTION! Before putting into service check the direction of rotation. Breakage may occur when the direction of rotation is wrong.



CAUTION! For the first one month or so, operate the machine at about 80% speed of its max. sewing speed.

CAUTIONS IN OPERATION

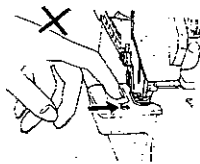

1. Do not put your hand under the needle when you turn on the power switch.

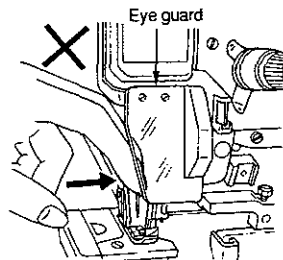

2. Do not put your hand into the eye guard section while the machine is running.

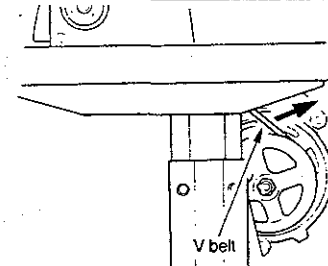

3. Be sure to turn off the power switch before you remove the V belt.



4. During operation, be careful not to allow your or any other person's head, hands or fingers to come close to the handwheel, V belt and motor. Also, do not place any instrument, tool or anything that is not necessary for sewing close to them. Doing so is dangerous.
5. If your machine is provided with a belt cover, finger guard, eye guard or any other protectors, do not operate your machine with any of them removed. Doing so is very dangerous.
6. Before inspecting, adjusting or cleaning the machine, threading the machine head or replacing the needle, be sure to turn OFF the power to the machine so as to prevent an accident and confirm that the sewing machine will not operate even when depressing the foot pedal of the sewing machine.
7. If your machine is equipped with a clutch type motor, the motor will be kept running by inertia after turning OFF the power switch. It is dangerous to depress the foot pedal of the sewing machine while the motor is still running, because the sewing machine will start rotating abruptly. Be sure to keep the foot pedal of the sewing machine held depressed after turning OFF the power switch until the sewing machine completely stops.
8. When you leave from your machine, make sure to turn OFF the power to it.
9. In case of a power failure, make sure to turn OFF the power to the machine.
10. Do not wipe the surface of the machine head with lacquer thinner.

1. INSTALLING THE FRAME SUPPORT PLATE

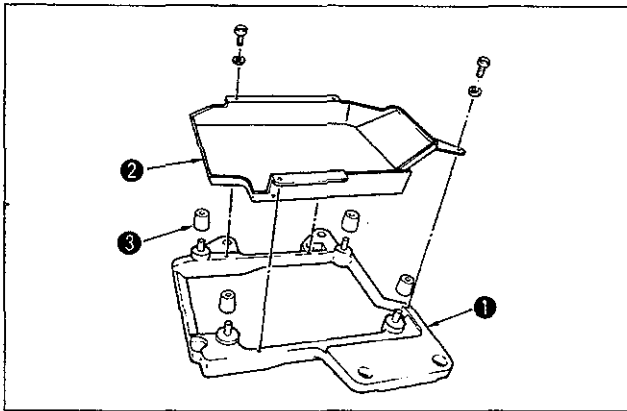

1) Attach blower case ②, rubber cushion ③ to frame support plate ①.

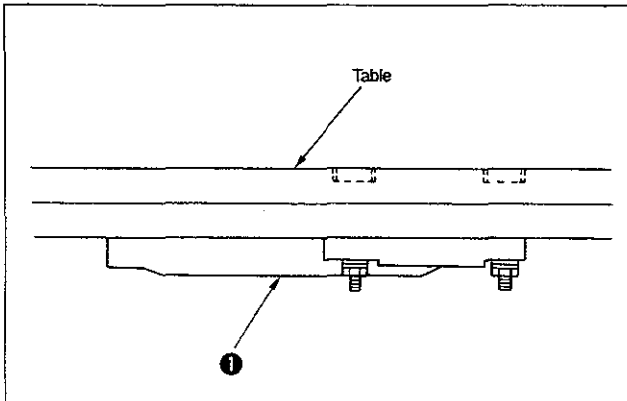

2) Install frame support plate ① directly to the table.

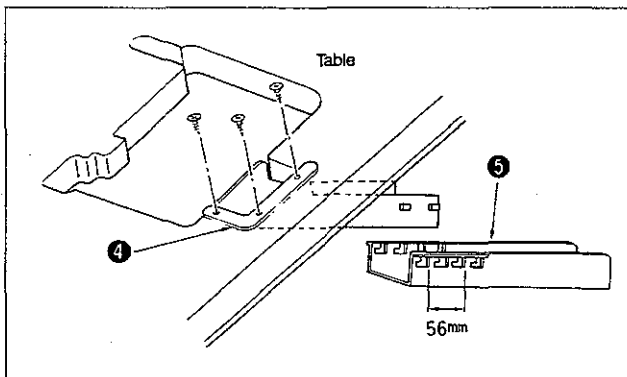

3) Install upper waste chute ④ to the left on the table, and then attach lower waste chute ⑤ to the upper waste chute. The installation of the chutes can be adjusted within a length of 56 mm.

2. MOTOR PULLEY AND V BELT

Sewing speed (s.p.m.)	50 Hz			60 Hz		
	Motor pulley outer dia. (mm)	V belt (inch)		Motor pulley outer dia. (mm)	V belt (inch)	
		Semi- sunken type	Fully- sunken type		Semi- sunken type	Fully- sunken type
8500	160.5	40	36	135.5	38	34
8000	150.5	40	34	125.5	38	32
7500	140.5	38	34	120.5	38	32
7000	130.5	38	34	110.5	36	32
6500	120.5	38	32	100.5	36	32
6000	110.5	36	32	95.5	35	30
5500	100.5	36	32	85.5	35	30
5000	90.5	35	30	80.5	34	30
4500	85.5	35	30	70.5	34	30

- 1) If the sewing speed of the machine exceeds 7,500 s.p.m., the machine is equipped with a clutch motor of 3/4 HP (550W). If it is 7,500 s.p.m. or lower, the machine is equipped with a clutch motor of 1/2 HP (400 W).
- 2) Use an M type V belt.
- 3) The table on the left shows the sewing speeds obtained by the use of motor pulleys with different diameters and V belts with different lengths.
- 4) Note that the effective diameter of the pulley of the machine head is 50 mm.

3. ATTACHING THE BELT COVER

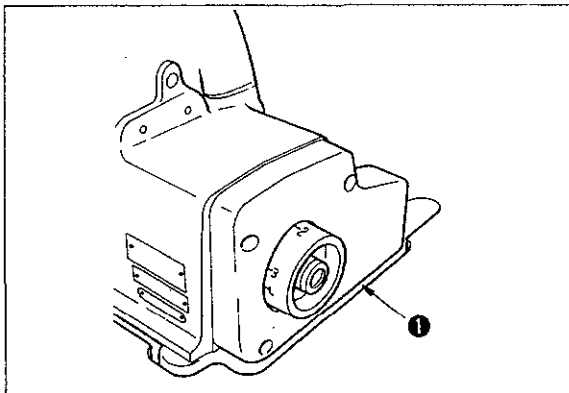

Install belt cover **1** to the machine head.

4. INSTALLING THE PEDALS

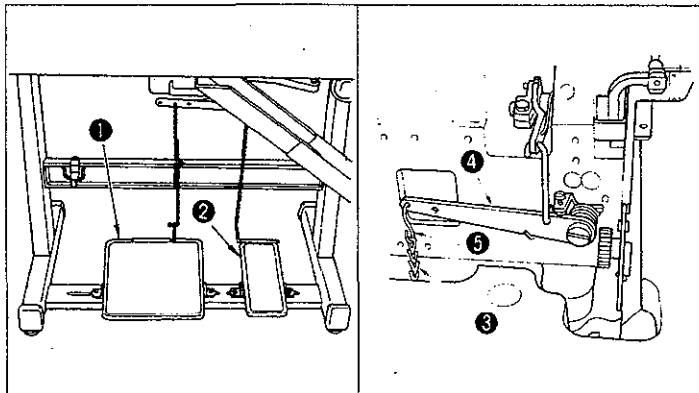

- 1) Install starting pedal **1** on the left and presser lifter pedal **2** on the right as seen from the operator.
- 2) Use an S-shaped hook **5** to connect the chain **3** of the presser lifter pedal to presser lifting lever **4**.

5. LUBRICATION

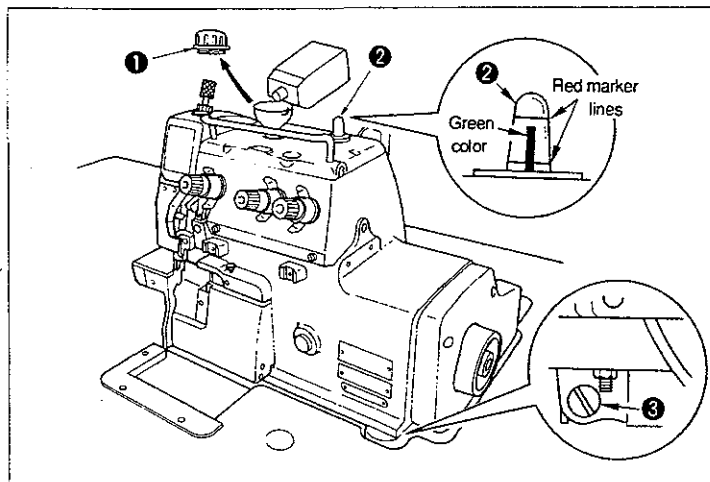

- 1) Remove oil cap **1**.
- 2) Pour JUKI New Defrix Oil No. 2 into the oil reservoir.
- 3) Supply oil until the pointer bar almost reaches the upper red marker line when oil gauge **2** is observed from the side.

Caution Be careful not to exceed the upper red marker line, or else troubles due to excessive lubrication may result.

- 4) Remove oil drain cap **3** when draining the oil reservoir.

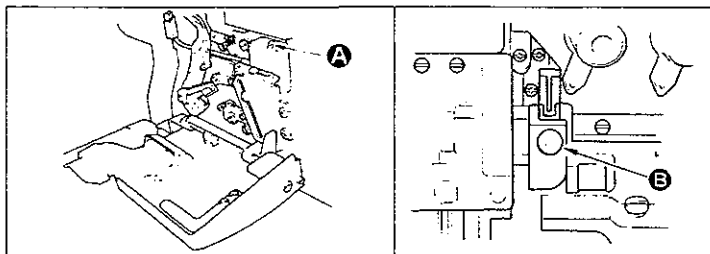

* Lubrication the needle cooler

- 1) Open cloth plate cover and supply silicon oil from section **A**.
- 2) Remove plug **B**, and supply silicon oil.
- 3) Infiltrate silicon oil also into the oil felt if the machine is started immediately after lubricating the needle cooler.

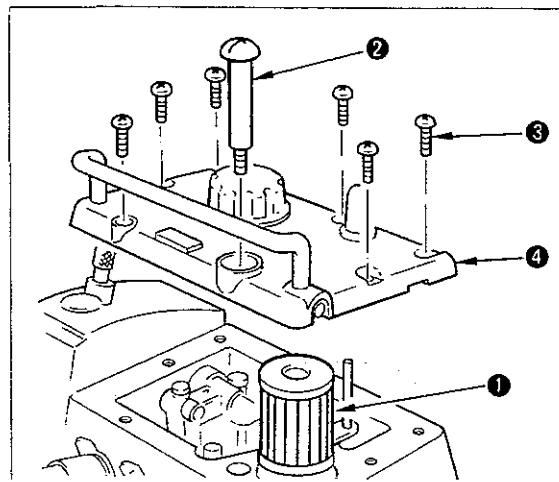

* Checking the cartridge filter and replacing it

1. After a long period of usage, cartridge filter **1** may become clogged with dust.

If the machine is left in this state, the dirty oil may fail to pass through cartridge filter **1**, and the machine may wear out abnormally, or a seizure may result.

* Cartridge filter **1** should normally be checked once every six months, and cleaned or replaced accordingly.

2. How to inspect the cartridge filter and replace it
 - 1) Remove first oil discharging screw **2**.
 - 2) Remove screws **3**, and lift top cover **4** just above until it comes off.
- (Caution) If top cover **4** is shifted sideward, the oil amount pointer bar and the cartridge filter may be damaged.
- 3) Remove cartridge filter **1** and check it. If the filter is found to be abnormal, clean the relevant components, or replace cartridge filter **1**.
 - 4) Re-insert cartridge filter **1** into its proper position and return the cover. Do not forget to put back the setscrews and tighten them up.

6. ATTACHING NEEDLES



Switch-off main switch before attaching needles! When using clutch motors without actuation lock wait until the motor has stopped totally!

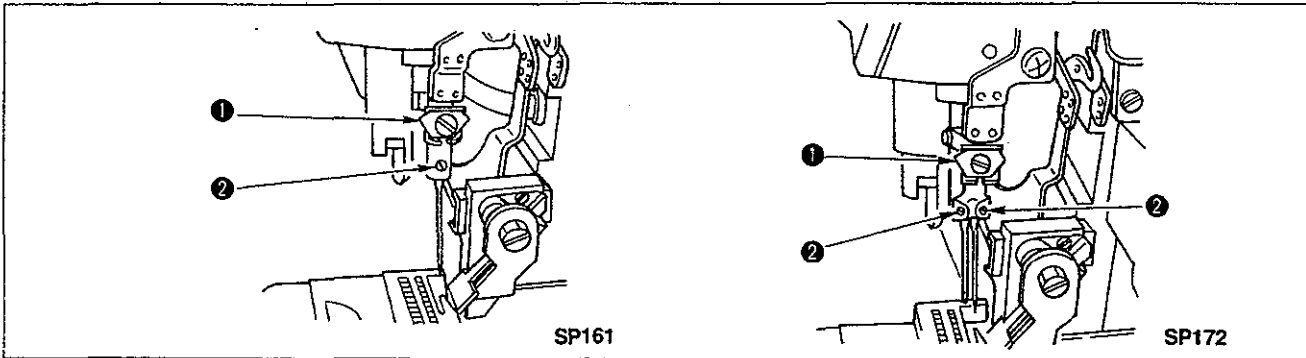

The standard needle is "DCx27 #11." You can also use the DCx1 needle. In this case, however, the clearance provided between the needle and the looper may be required to be adjusted. If sewing need to be carried out with a finely-adjusted thread tension, use the DCx27 needle.

Attach the needles according to the following procedure:

- 1) Bring needle clamp ① to the highest position.
- 2) Loosen needle clamp screw ②, and fully insert the needle into the needle clamp hole with the needle recess facing backwards as viewed from the operator's side.
- 3) Tighten the needle clamp screw ②.

7. THREADING THE MACHINE



Switch-off main switch before threading! When using clutch motors without actuation lock wait until the motor has stopped totally!

Thread the machine according to the threading chart given below. (The same chart is on the inside of the looper cover.)

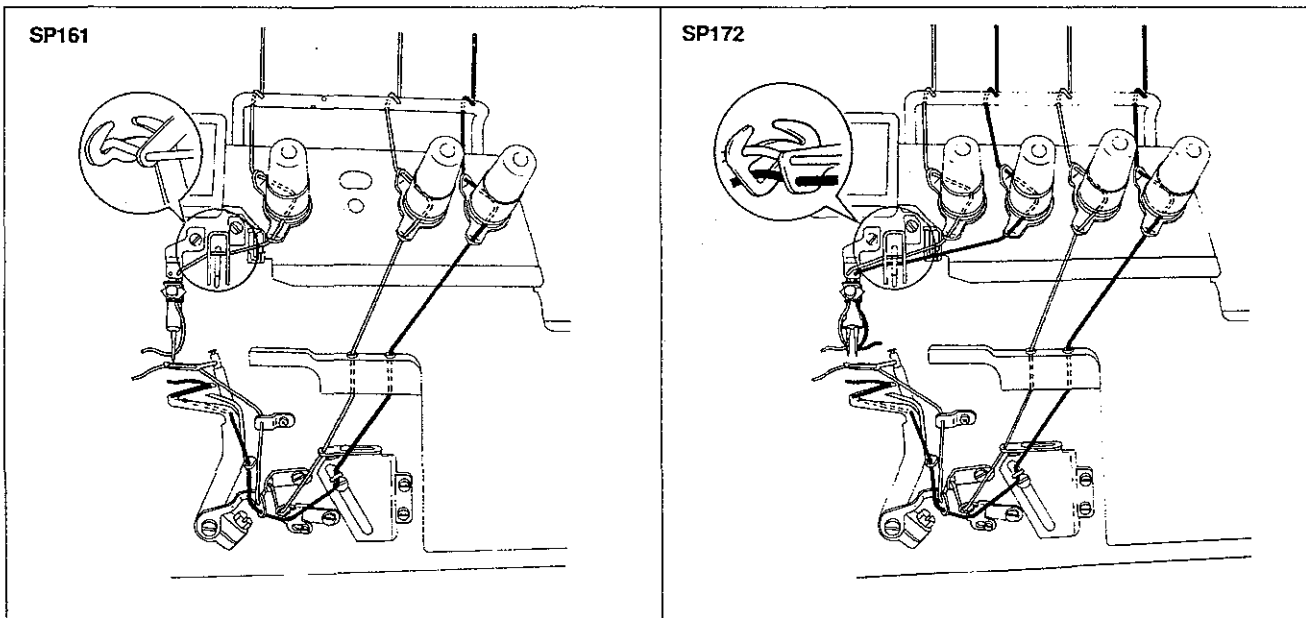

* How to thread the needle thread silicon oil tank

When the needle cooler is used

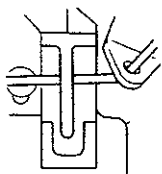

Pass the thread under the center pawl.

When the needle cooler is not used

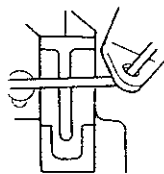

Pass the thread above the center pawl.

(Caution)

When using an untwisted thread such as wooly nylon thread or weak thread, do not wind it round the intermediate thread guide.

Intermediate thread guide

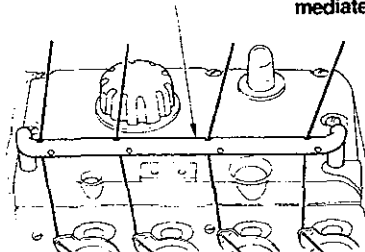

8. PRESSER FOOT PRESSURE AND LIFTER

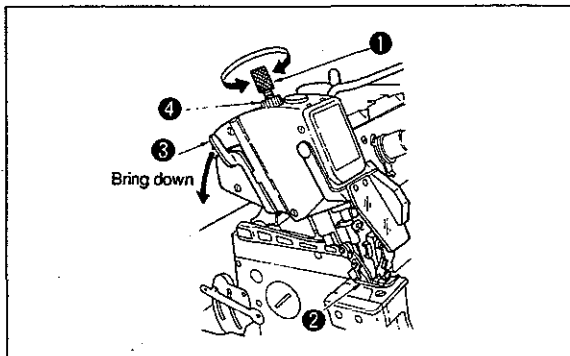

- 1) Adjust the pressure of the presser foot by loosening first nut ④ and turning presser foot adjust screw ①. When the adjust screw is turned clockwise, the pressure will increase. When it is turned counterclockwise, the pressure will decrease. After the adjustment, be sure to turn nut ④ without fail.
- 2) To open presser foot ② sideward, lower presser bar lifting lever ③.

9. ADJUSTING THE STITCH LENGTH

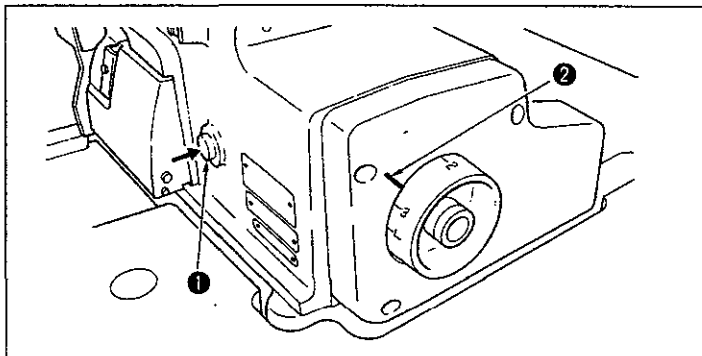

**Switch-off main switch before setting the stitch length!
When using clutch motors with-out actuation lock wait until the motor has stopped totally!**

- 1) Slowly turn the handwheel as you keep depressing pushbutton ①, and you will find a point at which the pushbutton goes in farther.
- 2) With the above condition maintained, align the desired scale mark on the handwheel with mark ② on the belt cover.
- 3) Reset the pushbutton after setting the dial.

10. DIFFERENTIAL FEED MECHANISM

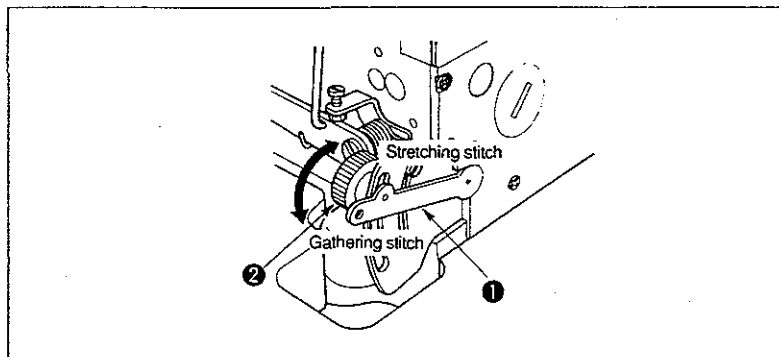

- 1) Loosen differential feed lock nut ②. Move lever ① up for stretching stitch or down for gathering stitch.
- 2) When the differential feed adjusting lever is set to graduation S, the machine will perform stretching with a differential feed ratio of 1:0.8. When the lever is set to graduation 0, the differential feed ratio between the main feed dog and the differential feed dog will be 1:1.
- 3) The maximum differential feed ratio for gathering is 1:2.3 (it can be set to 1:4.5 depending on the adjustment of the internal mechanism of the sewing machine). The graduations beyond 0 are used as reference.

11. KNIVES AND OVEREDGE WIDTH

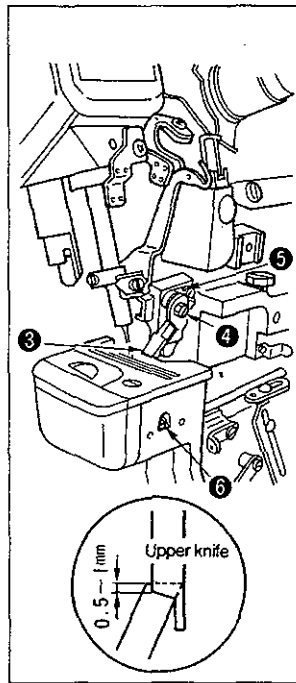
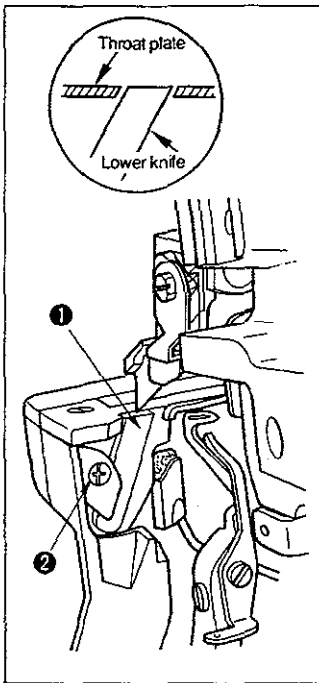

Switch-off main switch before adjusting the height of knives! When using clutch motors without actuation lock wait until the motor has stopped totally!

* Height of lower knife

Loosen setscrew ② and adjust the height of lower knife ① so that its edge is flush with the throat plate surface.

* Height of the upper knife

Loosen setscrews ④, ⑤ and perform adjustment so that upper knife ③ overlaps lower knife ① by 0.5 to 1 mm when the upper knife is at its lowest point.

* Overedge widths

Overedge widths of 2 through 4.8 mm are provided by changing the parts or by using subclass models. (The overedge width will be slightly larger than the knife cut width.)

To change the overedge width:

- 1) Loosening setscrew ⑥, push lower knife ① to the left and fix it.
- 2) Loosen setscrew ④ and move upper knife ③ as required, then fix it.
- 3) Lower the upper knife to its lowest point and loosen setscrew ⑥. Tighten setscrew ⑥ when the lower knife comes in contact with the upper knife.

1. Be sure to tighten screw ⑥ before operating machine.
2. After the completion of adjustment, make the knives cut a thread to check for sharpness of the knives.



(Caution)

* Resharpener the lower knife

When the lower knife has become dull, resharpen it as shown in the figure left.

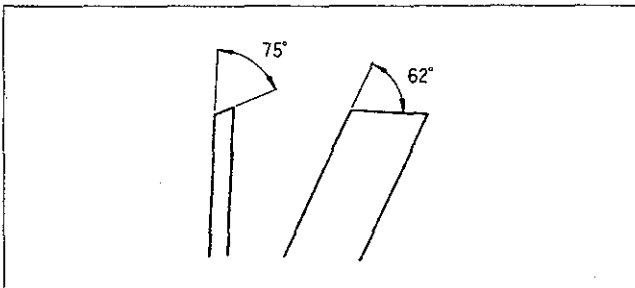

12. SPECIFICATIONS

	SP161	SP172
Sewing speed (Max.)	8,500 s.p.m.	8,000 s.p.m.
	(excluding some subclass models)	
Stitch length	0.8 - 3.5 mm	
Needle gauge	—	2.0, 2.4 mm
Overedge width	3.2, 4.0, 4.8 mm	2.0, 3.2, 4.0, 4.8 mm
Differential feed ratio	Gathering stitch 2.3 (Max. 1:4.5), Stretching stitch 1:0.8	
Needle	DC x 27 (Standard) DC x 1 may be used	
Presser foot lift	6.5 mm	7 mm
	(excluding some subclass models)	
Presser foot lift	JUKI New Defrix Oil No. 2	

Office use only	UNION SPECIAL CORPORATION PRODUCT INSTALLATION REPORT (Please submit one from each machine installed and complete all items)	Office use only
		Adjuster
	Customer _____ Date Installed _____ Address _____ Machine Style _____ _____ Serial number _____ _____ Installation Time _____ _____ (in hours) _____ Telephone _____ Sales Representative _____ Contact _____ Sales Territory _____	Inspector
		Style

SURVEY RATING PROCEDURE

Rate each of the items listed, circle one, according to the degree of satisfaction
 Highest = 5 (Very Satisfied): Lowest = 1 (Very Dissatisfied)

5 = Very Satisfied 2 = Dissatisfied*
 4 = Satisfied 1 = Very Dissatisfied* (*=Explanation Requested)

EVALUATION				
A. The carton and packing materials used are correct, all accessory items were received in good condition.	5	4	2	1
B. Sewing machine received in good condition No external parts or accessories were damaged in shipment.	5	4	2	1
C. The external painted surface was not scratched and showed no signs of rust at point.	5	4	2	1
D. There was no excessive accumulation of oil at any external part of the machine.	5	4	2	1
E. All screws and securing devices were tight. Adjustable parts were properly secured and did not become loose during initial operation of the machine.	5	4	2	1
F. Machine sewed on your operation out of the factory box with only minor adjustment required.	5	4	2	1
G. The instruction manual was informative and provided clear, easy to follow instructions.	5	4	2	1
H. The table stand, motor and accessory items provided for installing the machine were of proper design and suitable for your use of the machine.	5	4	2	1
I. In actual operation, under production standards, at maximum speed, the noise emitted was at acceptable levels. No unusual vibration was detected at the machine, motor or peripheral devices.	5	4	2	1

Please provide the reasons you are not satisfied with this product.

Item	Explanation
	(If more space is required, please use back of form.) Please enter operational data on back of form.

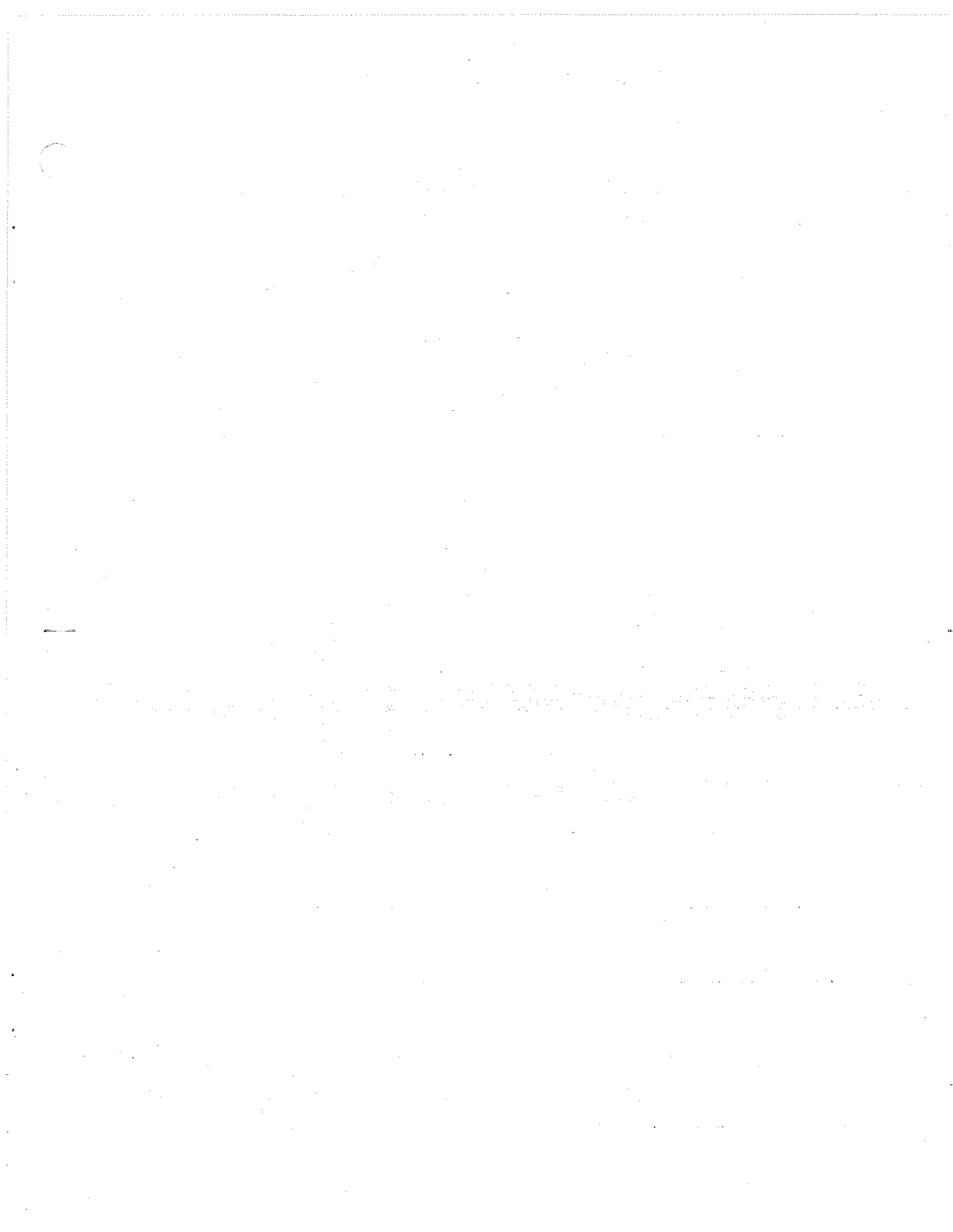

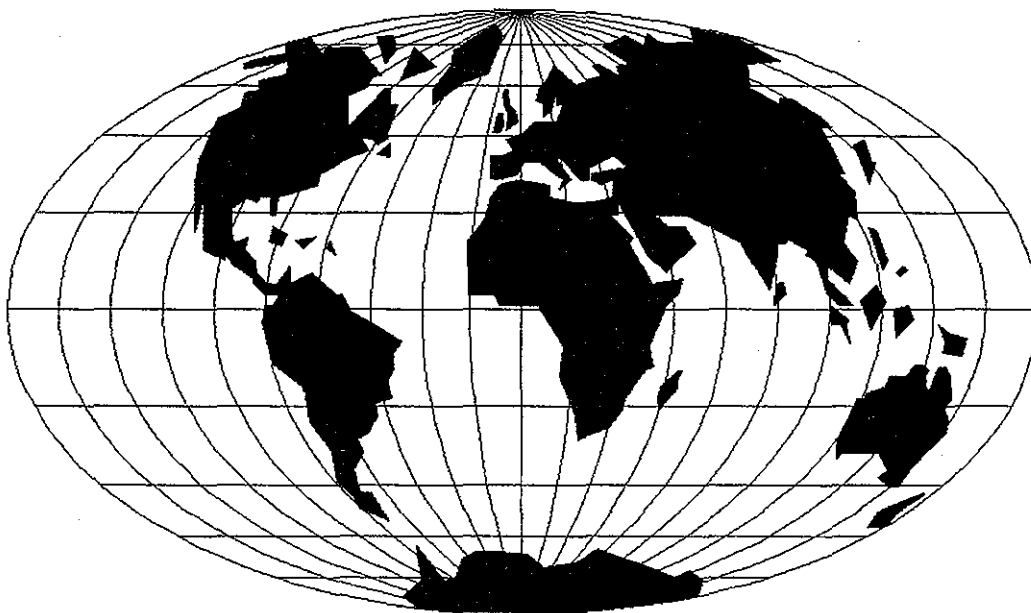

WORLDWIDE SALES AND SERVICE

Union Special Corporation maintains sales and service facilities throughout the world. These offices will aid you in the selection of the right sewing equipment for your particular operation. Union Special Corporation representatives and service technicians are factory trained and are able to serve your needs promptly and efficiently. Whatever your location, there is a qualified representative to serve you.

Corporate Office: One Union Special Plaza
Huntley, IL 60142
Phone: 847•669•5101
Fax: 847•669•4454

European Distribution Center: Union Special GmbH
Raiffeisenstrasse 3
D-71696 Möglingen, Germany
Tel: 49•07141•247•0
Fax: 49•07141•247•100

Brussels, Belgium
Charlotte, N.C.
El Paso, TX
Hong Kong, China
Huntley, IL
Leicester, England
Lille, France
Miami, FL
Milan, Italy
Möglingen, Germany
Montreal, Quebec
Osaka, Japan
Santa Fe Springs, CA

Other Representatives throughout
all parts of the world.



Union Special
INDUSTRIAL SEWING EQUIPMENT